



Keeping Industry Turning

Installation & Maintenance

W Ex ec & Ex tc Hazardous area motors



**BROOK
CROMPTON** 
Keeping Industry Turning

2437



WOLONG
Power your future

⚠ Warning

These motors are certified by a European Notified Body for use in hazardous atmospheres and should be installed, maintained and repaired (if necessary), strictly in accordance with the relevant standards and codes of practice of the user country for the repair and overhaul of Ex electrical apparatus. (For example, in UK: EN 60079-19 and recommendations outlined in the BEAMA /AEMT 'Code of Practice' for repair and overhaul of Ex electrical apparatus').

The certificates issued apply to motors as originally supplied, and in order to maintain validity, it is essential that any servicing/ repair be undertaken only by accredited establishments (see paragraph on 'Spares and Repairs'). Only genuine replacement parts can be used on these certified motors - always specify motor serial number, output (kW), RPM, voltage, Hz and mounting when ordering spares.

⚠ Warning

Qualified personnel only must undertake handling and lifting of electric motors. See additional sections of this manual and the customer safety and installation instructions. Full product documentation and operating instructions must be available together with tools and equipment necessary for safe working practice.

Note - before any work commences, reference should be made to the warning paragraph at the top of this page.

Receipt

Before any motor is accepted on site, it should be carefully inspected for damage or loss incurred during transit.

Wherever possible, damage should be recorded, photographed and witnessed. Report any findings to the carriers and Brook Crompton, quoting the motor number and consignment note reference.

Storage

If the motor is not to be used immediately, it should be stored in a clean, dry place which is vibration free. Temperature should be stabilised to -20°C to +40°C.

When drain holes are provided, they are supplied with a screwed, fitted plug.

Under no circumstances should the motor be located or operated in a hazardous environment with these plugs removed as the enclosure protection will be compromised.

⚠ Lifting

Eyebolts and/or lifting trunnions supplied with the motor are designed to support only the weight of the motor, not the weight of the motor and any ancillary equipment attached to it. Be absolutely sure that cranes, jacks, slings and lifting beams are capable of carrying the weight of equipment to be lifted.

Where an eyebolt is provided with the motor, this should be screwed down until its shoulder is firmly against the face of the stator frame to be lifted. Eyebolts are normally designed for a vertical lift.

Where two eyebolts are used with inclined loading, the maximum safe working loads should not be exceeded.

Bearings

To avoid static indentation (false brinelling), the storage area should be vibration free. Where exposure to some vibration is unavoidable, the shaft should be locked. Roller and thrust bearings are fitted with a shaft-locking device, which should be kept in place during storage.

Shafts should be rotated by hand (90°), weekly/ periodically.

Grease

Factory fitted regreaseable bearings use either Lithium or Polyurea based grease with a recommended shelf life of two years. If stored for a longer period, the grease may need to be replaced. Shielded bearings have a storage life of five years and a further two years operational life following installation.

Heaters

Where anti-condensation heaters have been fitted, it is strongly recommended that they are energised during storage. In such cases, prominent warnings of live terminals (inside the terminal box) must be posted inside and outside the terminal box.

Heaters must be isolated whilst the motor is energised, since the heaters, if energised, could cause the motor surface temperature to exceed the maximum for which it is certified. This would invalidate the certification and could result in ignition of the surrounding atmosphere. Heaters must be de-energised before opening any part of the motor enclosure.

Where the certificate permits, the winding may be energised at a low voltage as an alternative to anti-condensation heaters (for maximum voltage see marking on motor). The mains supply must be disconnected during these periods.

Where anti-condensation heaters are not fitted, the use of a desiccant is recommended.

Installation

⚠ Withdrawal from storage

Before taking any motor from storage, ensure that anti-condensation heaters (if fitted), have been disconnected and isolated before moving the motor. Check that no foreign matter is present and remove all surface dust and dirt.

Test the stator insulation resistance between phases and also to earth. If an insulation resistance of lower than ten Megohms at 20°C is measured, the windings must be dried out. Any such tests must not be carried out whilst there is risk of the presence of an explosive atmosphere. After measurement, the windings should be discharged immediately to avoid the risk of electric shock.

Location

Motors must be installed with adequate access for routine maintenance. A minimum of 0.75m of working space around the motor is recommended. Adequate space around the motor, particularly at the fan inlet (50mm), is also necessary to facilitate airflow.

Where several motors are installed in close proximity or other heat sources are present, care must be taken to ensure that there is no recirculation of exhausted warm air. Foundations must be solid, rigid and level.

On motors which are mounted vertically with the output shaft facing upwards, the driven equipment must prevent falling objects from entering the fan housing.

⚠ B14 (IM3601 & B34 (IM2101)

Where a motor is fitted with a 'C' face flange, ie B14 or B34 mounted, care must be taken to ensure mounting bolts do not protrude beyond the 'C' face casting thickness.

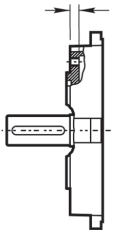

⚠ Electrical connection

The connection diagram is shown on the leaflet enclosed in the motor terminal box or the diagram inside the terminal box lid. The cables used should be capable of carrying the full load current of the motor (see motor nameplate), without overheating or undue voltage drop.

Cable terminations

All cable terminations should be tightly secured. There should be no nuts or lock washers fitted between the mains and the motor lugs.

Permanently attached cables shall be suitably protected against mechanical damage and terminated within the terminal or junction facility suitable for the conditions of use.

Wiring should be carried out or checked by a qualified electrician and equipment must be earthed in accordance with current regulations.

Typical terminal board arrangement

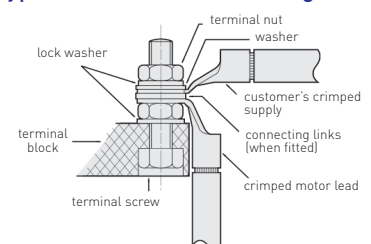

Terminal nut torque			
Frame Size	Terminal Nut	Torque (Nm)	Torque (lb-ft)
63 - 100	M4	1.1	0.8
112 - 132	M5	2.2	1.6
160 - 180	M6	3.8	2.8
200 - 355	M10	12	8.9

Installation & Maintenance

Installation / Maintenance

When the motor is despatched with plastic plugs fitted into the cable entry holes, these plugs **must** be removed prior to commissioning and a suitably certified gland inserted. Cable entries are not to be left open, therefore if any holes are unused or made redundant, they must be plugged with a suitably certified and correctly inserted stopping plug (stopping plugs to be removed only with the aid of a tool).

Alternatively, a replacement gland plate or terminal box must be obtained from Brook Crompton. All cable glands/conduit/plugs etc, must have at least the same IP rating and the hazardous area certification as the motor, thereby ensuring that the motor certification and protection are not compromised.

Note - the operating temperatures at the conduit or cable entry may exceed 70°C and at the branching point of the conductors may exceed 80°C under rated conditions.

If aluminium cables are used they must be terminated in such a way, as to ensure protection against corrosion due to dissimilar metals. Earth bonding of the motor, both on the motor frame and inside the terminal box, should always be carried out to eliminate the risk of electrostatic discharges from the motor.

Bearings

Ball and roller bearings are despatched from the works fully charged with grease. Shielded bearings have sufficient grease for an operating life of at least two years in normal ambient temperatures, providing there is little or no grease leakage.

On motors with re-lubrication facilities, replenish with a compatible grease but take care to avoid overfilling the bearing housings. It should be noted that over greasing presents a far greater hazard to trouble-free service than under greasing but careful attention is a mandatory requirement. Bearings without re-lubrication facilities will eventually need replacing.

When changing bearings, it is essential to replace shaft seals that are of the same size, type and material as originally fitted. Care should be taken to ensure that shaft seals are not damaged during fitting and that the lips are lubricated. For details of which seals are used, please contact Brook Crompton.

Fitting pinions, pulleys and couplings

These should be stored to suit the shaft diameter.

⚠ Warning

Tapping of fitments onto the motor shaft with a hammer or mallet, causes bearing damage. This results in an increase in bearing noise and a significant reduction in bearing life.

Re-lubrication

Recommended re-lubrication intervals are available on request as these are load dependant. When replenishing, use a type that is compatible to the grease detailed on the motor nameplate. (See Re-lubrication table).

When the ambient temperature is outside the normal operating range of the grease, see rating plate for re-lubrication details.

Maintenance

⚠ Warning

Isolate power supply to motor before commencing any routine cleaning or maintenance work.

Routine Cleaning

The time intervals between inspections should be sufficiently regular (to be decided by the user but not exceeding three months for combustible dust environments), so as to ensure that the user can be alerted to excessive build up of accumulated layers of dust on the equipment surface. Routine cleaning should include but not be limited to the following:

- a) Remove the fan cover and ensure that all air inlet holes are completely free.
- b) Clean any dust or dirt and obstructions from behind the fan and along the ribs of the frame.

Tightening torques and bolt sizes can be obtained from Brook Crompton.

On-going Cleaning

- a) As routine cleaning first.
- b) That no visible damage has occurred to the motor, ie cracked or broken components, bent fan cowl, loose components etc.
- c) Running clearances are adequate.
- d) No significant corrosion of the lifting facilities
- e) No excessive vibration.
- f) No loose bolts or fasteners.
- g) Cables and earths are sound.
- h) Sealing of the motor and gland plate are in good condition. This is to include the condition of the gaskets, shaft seal and jointing compound.
- i) Insulation resistance is adequate. It is imperative that this is checked prior to starting and after prolonged shut down.
- j) Regreasing or replacement of bearings if normal life is exceeded.

Re-lubrication Table		
Frame Size	Grease	Type
71 - 355	Esso Unirex N3	Lithium Complex
	NSK EA6	Polyurea
<small>Note: Lithium complex type greases are not compatible with Polyurea type greases - refer to nameplate</small>		

Standard re-greasing facility	
Frame Size	Facility
71	Sealed for life bearings
80 - 180	Re-grease on request
200 - 315	Re-grease facility as standard

See page _ for re-lubrication intervals for motor frame sizes 200 - 355 using Esso Unirex grease.

Installation & Maintenance

4 Maintenance

Periodic Cleaning

- a) As routine cleaning first.
- b) Remove the fan cover and the fan. Loosen and remove bearing cap screws and endshield screws/studs. The endshields should then be eased off their spigots and removed.
- c) The rotor can now be carefully withdrawn from the stator - taking care not to damage the stator bore, the stator winding and the rotor.
- d) Having dismantled the motor, maintenance can be carried out to remove all dirt. For this purpose, the use of an air line supplying dry compressed air under comparatively low pressure is best as a high velocity air stream can force dirt into the spaces between the windings and insulation etc. Grease removing solvents should only be used very sparingly to avoid damage to impregnation varnish or insulation.
- e) For lubrication details, refer to earlier 'Installation' paragraph.
- f) Motors should be re-assembled in the reverse order from dismantling, remembering to ease endshields onto bearings and spigots. Do not use force. All shafts and gaskets should be replaced using identical components to those originally fitted. If required, the enclosure joints faces should be liberally coated with a suitable non-setting gaskets and jointing compound to ensure the integrity of the enclosure.

The following lists are joint faces to be coated with gasket and jointing compound for motors used in Zone 21 or 22:

- 1) Motors with IP55 enclosure for use in Zone 22 environments where dust is non-conductive, remove drain plugs.
- 2) Motors with IP65 enclosure for use in Zone 21 and 22 (with conductive dusts):
 - i) Stator frame to endshield spigot face - drive end and non-drive end, and where appropriate:
 - ii) Stator frame to terminal box and/or conduit facing.
 - iii) Terminal box body to terminal box lid.
 - iv) Terminal box to spreader box/gland plate.
 - v) Spreader box to gland plate.
 - vi) Removeable drain plugs.

Further, soft copper washers should be replaced to inner bearing cap and gland plate fixing screws.

- g) Before starting, check that the rotor revolves freely. Ensure that the electrical connections are correct and terminal nuts tight (see section - 'Electrical Connection'.
- h) Refit any pulley, coupling sprocket etc, which has been removed - being particularly careful to ensure correct alignment with the driven part, as misalignment will lead to ultimate bearing trouble and shaft breakage.
 - i) When replacing screws and bolts, care should be taken to use only those with the requisite quality and tensile strength recommended by the manufacturer. A minimum grade of 8.8 is required for all fixing screws except socket head cap screws which must be a minimum of grade 12.9. These must also be of identical thread form and screw/bolt length. A marginally longer bolt, screwed into a blind hole could 'bottom' and prevent correct closure of a joint. Recovering of tapped holes by counter drilling and fitment of propriety inserts is not recommended by Brook Crompton.

The practices given in IEC 60079-14 and the AEMT/BEAMA repair code should be followed for inspection of components and the treatment of corrosion during maintenance.

Spares and repairs

When ordering spares, it is important to state the motor serial number to ensure that the correct spares will be supplied.

Notes:

- a) Fixing bolts, nuts, studs, screws, spacers or washers are not included with these parts and, if required, should be clearly specified on the order in addition to the part description number. The fixing duty and part description reference number for which they are required should also be clearly stated.
- b) Bearings ordered direct from bearing manufacturers must be specified as follows: 'ISO CN, ISO C3', with bearing size. (Bearing fit to be as original motor drawing).

Responsibility for the validity of certification after repair work or the fitting or spares rests with the user. Such repairs should be carried out by competent engineers who are fully trained in working on equipment for hazardous areas.

- 1) Personnel have attended a course appropriate to the codes of practice and standards of the nation where the motor is installed. This will normally be a course recognised by the national trade association, health and safety inspectorate or certifying authority (eg, in the UK the AEMT course 'Repair and Overhaul of Ex Electrical Apparatus').
- 2) The workshop is approved by Brook Crompton's authorised repair agent liaison officer or is otherwise suitably accredited by a nationally recognised competent authority.

Where the motor has been originally repaired as indicated by symbol 'R' in accordance with the code*, or IEC 60079-19, details of the repair should be obtained from the user / repairer before proceeding with repair. Alternatively, contact Brook Crompton.

*See AEMT/BEAMA publication No. 300 - 'Code of Practice for Repair and Overhaul of Electrical Apparatus'.

W Series Modifications

Details on how to modify W motors can be obtained from Brook Crompton. Responsibility for the validity of certification after any modifications rests with the user. Such modifications should be carried out by competent engineers who are fully trained in working on equipment for hazardous areas.

Installation & Maintenance

Inspection Schedule

Terminal nut torque		Inspection Category*	
Check that		Initial	Periodic
	Apparatus is appropriate to area classification	A	A
	Surface temperature is correct	A	A
	Apparatus subgroup (if any) is correct	A	A
1	Apparatus carries the correct circuit identification	A	B
	Enclosures are satisfactory and undamaged	A	A
	There are no unauthorised modifications	A	A
	Bolts, glands and stoppers are complete and tight	A	A
	Obstructions do not conflict with IEC 60079-14	A	A
	Enclosure seals are satisfactory	A	A
	Gaps are free from corrosion, dirt and paint	A	A
2	There is no undue accumulation of dust or dirt	B	B
	All conduit runs and fitting are tight and free from corrosion	A	B
	Earthing is satisfactory	A	A
	Condition of enclosure gaskets are satisfactory	A	B
	Electrical connections (used and unused) are tight	A	B
	Motor airgaps and other running clearances are satisfactory	A	A
	Electrical protection is satisfactory, overcurrent protection etc.	A	A
3	There is no obvious damage to cables, cable sheaths or cable glands	A	A
	Apparatus is adequately protected against corrosion, the weather, vibration and other adverse factors	A	A
	Guards (where used) are present and correctly fitted	A	A
	Fan cowl undamaged and fitted correctly	A	A
	Only 1 single or multistrand lead may be connected to either side of any auxiliary terminal, unless multiple connectors have been joined in a single insulated crimped bot lace ferrule	A	A
	Leads to auxiliary blocks are to be minimum of 1.0mm ² when connected to heaters, thermistors or thermostats	A	A
	Ensure that only one lead is connected to either side of the auxiliary terminal block	A	A
	Circuits carry > 1 amp shall be individually and suitably overcurrent protected	A	A
	Connecting leads must be insulated for the appropriate voltage and the insulation must extend to within 1mm of the metal terminal.	A	A
	The suitability of the plastic fan material for certain solvents should be ascertained by the user	A	B

Notes:

- 1) Apparatus must be positively identified with its circuit to ensure that correct isolation can be carried out.
- 2) Accumulation of dust or dirt can interfere with heat dissipation and result in surface temperature higher than those permitted in the hazardous area.
- 3) Particular attention should be paid to flexible cables used with portable apparatus.

*Category A inspections should be carried out in all cases. Category A intervals must not exceed 2 years. More frequent and/or more detailed inspection will be necessary where there is a corrosive or other adverse atmosphere, a high risk of mechanical damage or vibration, or where there are other onerous circumstances. The need for more frequent inspection may also be determined by operating experience.

The need for, the method, and the frequency of category B inspections is at the discretion of the engineer responsible. It is not intended that periodic inspections should incur undue disturbance of apparatus unless considered necessary by the engineer responsible.

Installation & Maintenance

6 Regreasing Intervals

Bearing grease and re-lubrication intervals

Bearings are pre-packed with a grease type dependant on frame size.

Generally standard motors frame sizes 63 to 180 are sealed for life bearings.

Sealed for life bearings can be identified on the motor name plate with 'ZZ' or 'ZZ' appearing after the bearing size for example 6310ZZ.

Motor frames sizes 100 to 180 could have an option to include re-lubrication facilities.

To quote re-lubrication intervals for these frame sizes please contact the sales office, quoting either a part number or motor serial number from the motor nameplate.

Motor frame sizes 200 to 355 are supplied with re-lubrication facilities, the re-lubrication intervals are shown in the tables below.

Re-lubrication intervals on a 50Hz supply x 10 ³ hours - Grease type: Esso Unirex												
Motor Type		DE Bearing	NDE Bearing	Grease qty (gms)	3000min ⁻¹		1500min ⁻¹		1000min ⁻¹		750min ⁻¹	
European	BS				Horizontal	Vertical	Horizontal	Vertical	Horizontal	Vertical	Horizontal	Vertical
WU/WP-UDF200LX	W/WP-DF200LX	6312	6312	20	14.8	9.6	30.0	21.3	30.0	29.3	30.0	30.0
WU/WP-UDF225S	W/WP-DF225S	6313	6313	23	12.6	8.2	30.0	20.3	30.0	27.8	30.0	30.0
WU/WP-UDF225M	W/WP-DF225M	6314	6314	26	11.3	7.4	29.5	19.2	30.0	26.0	30.0	30.0
WU/WP-UDF250ME ^[2P]	W/WP-DF250S ^[2P]	6314	6314	26	12.6	8.2	-	-	-	-	-	-
WU/WP-UDF250ME	W/WP-DF250S	6316	6316	33	-	-	26.3	17.1	30.0	23.6	30.0	29.3
WU/WP-UDF280SE ^[2P]	W/WP-DF250M ^[2P]	6314	6314	26	11.3	7.4	-	-	-	-	-	-
WU/WP-UDF280SE	W/WP-DF250M	6318	6318	41	-	-	23.4	15.2	30.0	21.3	30.0	27.8
WU/WP-UDF280ME ^[2P]	W/WP-DF280S ^[2P]	6314	6314	26	11.3	7.4	-	-	-	-	-	-
WU/WP-UDF280ME	W/WP-DF280S	6318	6318	41	-	-	23.4	15.2	30.0	21.3	30.0	27.8
WU/WP-UDF315SE ^[2P]	W/WP-DF280M ^[2P]	6316	6316	33	9.4	6.1	-	-	-	-	-	-
WU/WP-UDF315SE	W/WP-DF280M	6319	6319	45	-	-	21.3	13.8	30.0	20.3	30.0	26.0
WU/WP-UDF315ME ^[2P]	W/WP-DF315S ^[2P]	6316	6316	33	9.4	6.1	-	-	-	-	-	-
WU/WP-UDF315ME	W/WP-DF315S	6319	6319	45	-	-	21.3	13.8	30.0	20.3	30.0	26.0
WU/WP-UDF315M/L ^[2P]	W/WP-DF315M/L ^[2P]	6316	6316	33	9.4	6.1	-	-	-	-	-	-
WU/WP-UDF315M/L	W/WP-DF315M/L	6319	6319	45	-	-	21.3	13.8	30.0	20.3	30.0	26.0
WU/WP-UDF355S/M/L ^[2P]	W/WP-DF355S/M/L ^[2P]	N316	6316	33	5.0 ^[0] /9.4	3.3 ^[0] /6.1	-	-	-	-	-	-
WU/WP-UDF355S/M/L	W/WP-DF355S/M/L	N324	6324	71	-	-	8.2 ^[0] /13.5	5.3 ^[0] /8.8	16.2 ^[0] /22.5	10.5 ^[0] /14.6	24.5 ^[0] /30.0	15.9 ^[0] /19.5

^[2P] = 2 pole motor
^[0] = Drive end bearing

Re-lubrication intervals on a 60Hz supply x 10 ³ hours - Grease type: Esso Unirex												
Motor Type		DE Bearing	NDE Bearing	Grease qty (gms)	3600min ⁻¹		1800min ⁻¹		1200min ⁻¹		900min ⁻¹	
European	BS				Horizontal	Vertical	Horizontal	Vertical	Horizontal	Vertical	Horizontal	Vertical
WU/WP-UDF200LX	W/WP-DF200LX	6312	6312	20	10.0	6.5	27.5	17.9	30.0	26.0	30.0	30.0
WU/WP-UDF225S	W/WP-DF225S	6313	6313	23	8.0	5.2	26.3	17.1	30.0	24.4	30.0	29.3
WU/WP-UDF225M	W/WP-DF225M	6314	6314	26	7.5	4.9	25.0	16.3	30.0	22.8	30.0	27.6
WU/WP-UDF250ME ^[2P]	W/WP-DF250S ^[2P]	6314	6314	26	7.5	4.9	-	-	-	-	-	-
WU/WP-UDF250ME	W/WP-DF250S	6316	6316	33	-	-	22.0	14.3	30.0	21.1	30.0	25.7
WU/WP-UDF280SE ^[2P]	W/WP-DF250M ^[2P]	6314	6314	26	7.5	4.9	-	-	-	-	-	-
WU/WP-UDF280SE	W/WP-DF250M	6318	6318	41	-	-	17.5	11.4	29.0	18.9	30.0	24.1
WU/WP-UDF280ME ^[2P]	W/WP-DF280S ^[2P]	6314	6314	26	7.5	4.9	-	-	-	-	-	-
WU/WP-UDF280ME	W/WP-DF280S	6318	6318	41	-	-	17.5	11.4	29.0	18.9	30.0	24.1
WU/WP-UDF315SE ^[2P]	W/WP-DF280M ^[2P]	6316	6316	33	5.3	3.4	-	-	-	-	-	-
WU/WP-UDF315SE	W/WP-DF280M	6319	6319	45	-	-	16.3	10.6	27.5	17.9	30.0	22.8
WU/WP-UDF315ME ^[2P]	W/WP-DF315S ^[2P]	6316	6316	33	5.3	3.4	-	-	-	-	-	-
WU/WP-UDF315ME	W/WP-DF315S	6319	6319	45	-	-	16.3	10.6	27.5	17.9	30.0	22.8
WU/WP-UDF315M/L ^[2P]	W/WP-DF315M/L ^[2P]	6316	6316	33	5.3	3.4	-	-	-	-	-	-
WU/WP-UDF315M/L	W/WP-DF315M/L	6319	6319	45	-	-	16.3	10.6	27.5	17.9	30.0	22.8
WU/WP-UDF355S/M/L ^[2P]	W/WP-DF355S/M/L ^[2P]	N316	6316	33	2.3 ^[0] /5.3	1.5 ^[0] /3.4	-	-	-	-	-	-
WU/WP-UDF355S/M/L	W/WP-DF355S/M/L	N324	6324	71	-	-	5.0 ^[0] /9.0	3.3 ^[0] /5.9	12.5 ^[0] /18.8	8.1 ^[0] /12.2	18.5 ^[0] /25.0	12.0 ^[0] /16.3

^[2P] = 2 pole motor
^[0] = Drive end bearing

The data quoted in the tables above is based on 70°C. These intervals should be halved for every 15°C above 70°C.

Installation & Maintenance

Typical Ex ec Cast Iron Motor

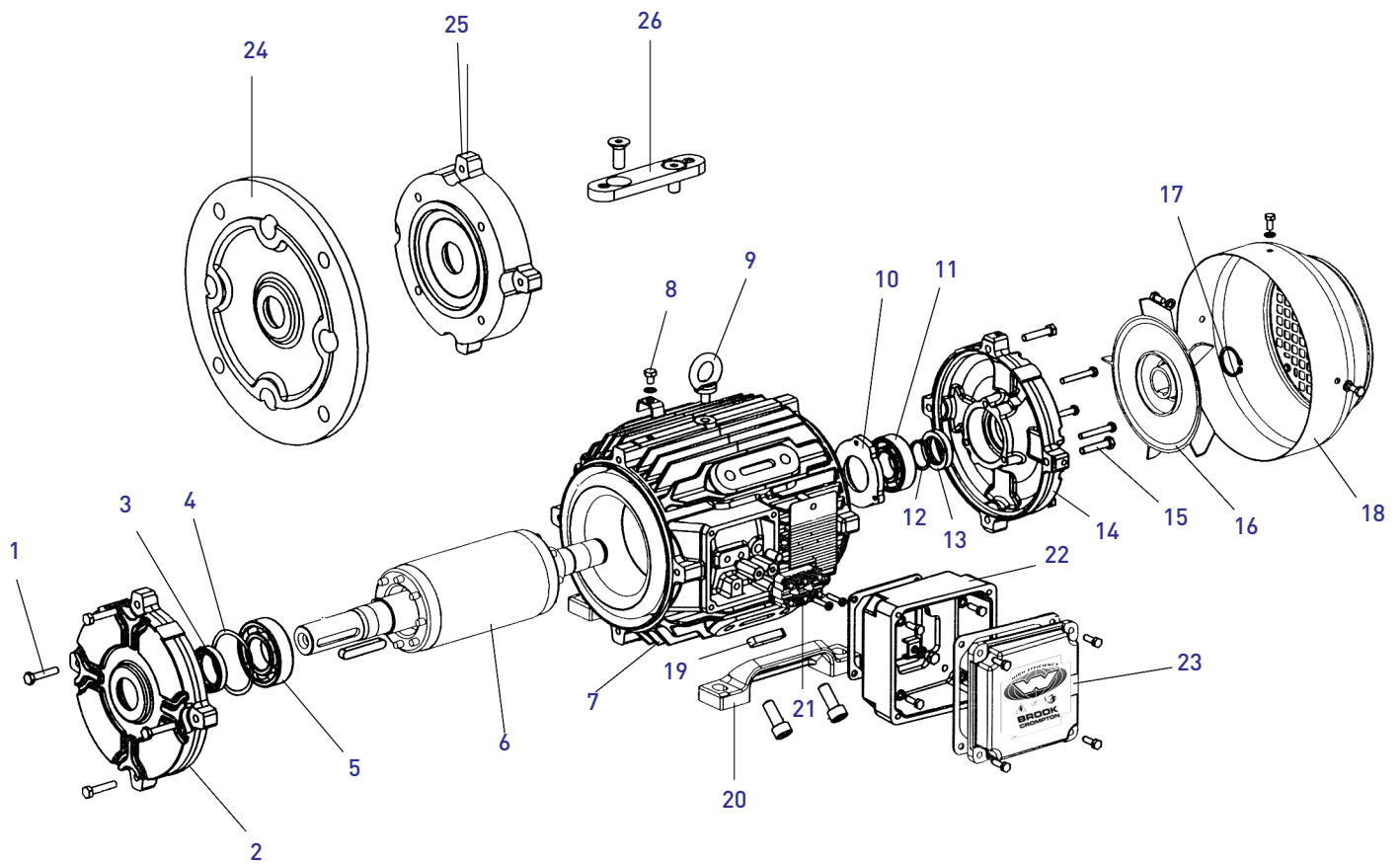

Ref.	Part Description
1	Drive end endshield fixing screws
2	Drive end endshield
3	Drive end oilseal
4	Preloaded washer
5	Drive end bearing
6	Rotor assembly
7	Stator assembly with or without feet
8	Earth terminal
9	Eyebolt

Ref.	Part Description
10	Non-drive end bearing cap (when fitted)
11	Non-drive end bearing
12	Bearing circlip
13	Non-drive end oilseal
14	Non-drive end endshield
15	Non-drive end endshield fixing bolts
16	Fan
17	Fan circlip
18	Fan Cover

Ref.	Part Description
19	Foot locking method (when fitted)
20	Bolt-on-feet and bolts
21	Terminal board and fixing screws
22	Terminal box, gasket and fixing screws
23	Terminal box lid, gasket and bolts
24	Flange endshield
25	Face endshield
26	Bolt-on-pad

Cable Entries

Motor frame sizes 71 to 180 will be supplied with cable entries pre-drilled in the terminal box.

Motor frame sizes 200 to 355L motors will be supplied with a blank gland plate as standard.

The following 4 pages show how to identify the gland plate fitted to the motor and the maximum number of tapped holes along with the maximum size of tapped hole for each gland plate.

The number of holes and layout must be adhered to when drilling the gland plate.

Please note as part of the special conditions for safe use for these range of motors. **'Any unused cable entries shall be blanked using approved cable blanks'**

Gland Plate Identification

Particular motor designs may be fitted with an oversize terminal box, therefore, fitted with a larger gland plate than standard.

It is important that before any machining work is carried out on the gland plate, that the correct gland plate is identified.

The drawings below give the basic dimensions of the three different gland plates fitted to the 'W' range of motors from frame sizes 200 to 355L.

Please check the dimensions of the gland plate before drilling to identify the correct gland plate fitted to the motor.

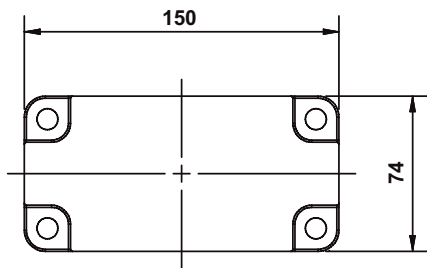

Gland part number
T1RGA

see page 9 for
drilling details

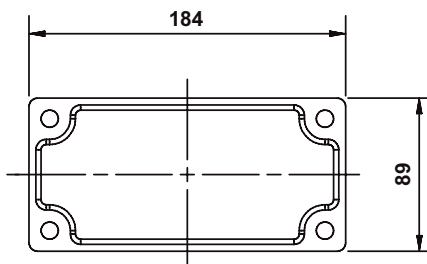

Gland part number
W1RGA

see page 10 for
drilling details

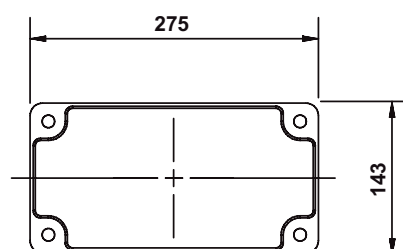

Gland part number
W4LGA

see page 11 for
drilling details

Installation & Maintenance

Allowable Cable Entries on Gland Plate T1RGA

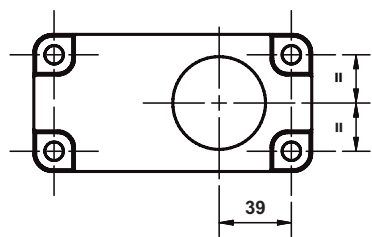

1 main entry
maximum entry size
CM50

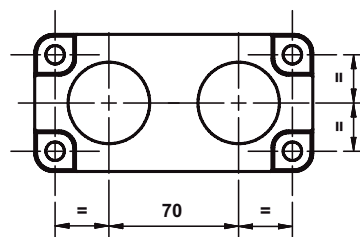

2 main entries
maximum entry size
CM40

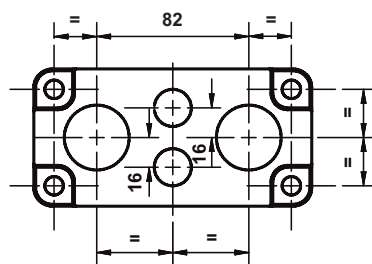

2 mains & 2 auxiliaries
maximum main entry size
CM32
auxiliary entry size
CM20

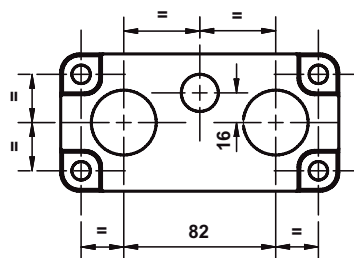

2 mains & 1 auxiliary
maximum main entry size
CM32
auxiliary entry size
CM20

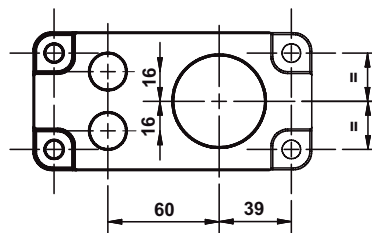

1 main & 2 auxiliaries
maximum main entry size
CM50
auxiliary entry size
CM20

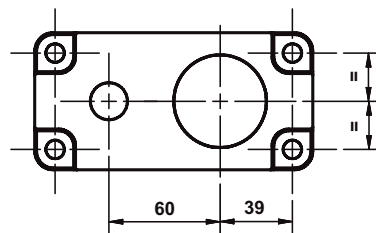

1 main & 1 auxiliary
maximum main entry size
CM50
auxiliary entry size
CM20

The drilling and tapping sizes quoted above are for use on gland plate part number T1RGA only.

Please note as part of the special conditions for safe use for these range of motors.

'Any unused cable entries shall be blanked using approved cable blanks'

Installation & Maintenance

Allowable Cable Entries on Gland Plate W1RGA

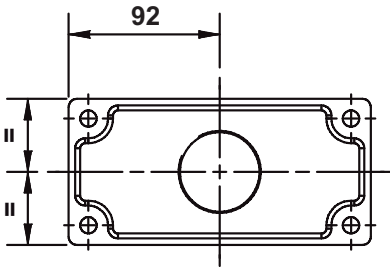

1 main entry
maximum entry size
CM50

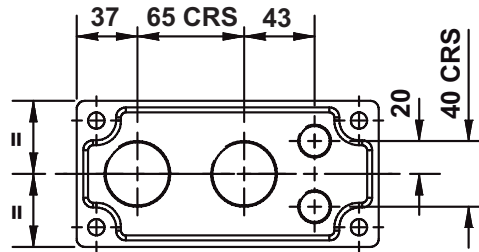

2 mains & 2 auxiliaries
maximum main entry size
CM40
auxiliary entry size
CM20

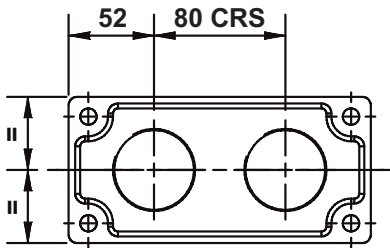

2 mains entry
maximum entry size
CM50

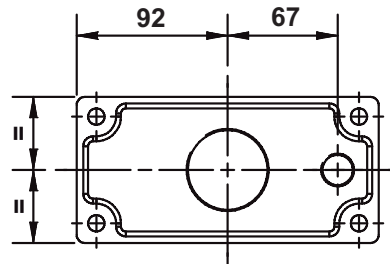

1 main & 1 auxiliary
maximum main entry size
CM50
auxiliary entry size
CM20

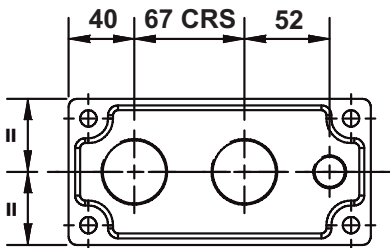

2 mains & 1 auxiliary
maximum main entry size
CM40
auxiliary entry size
CM20

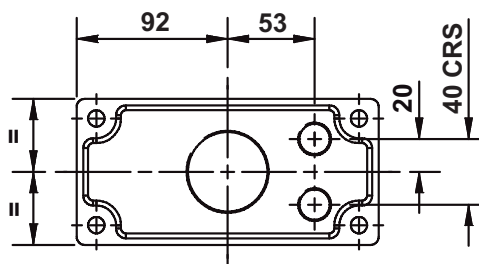

1 main & 2 auxiliaries
maximum main entry size
CM50
auxiliary entry size
CM20

The drilling and tapping sizes quoted above are for use on gland plate part number W1RGA only.

Please note as part of the special conditions for safe use for these range of motors.

'Any unused cable entries shall be blanked using approved cable blanks'

Installation & Maintenance

Allowable Cable Entries on W4LGA

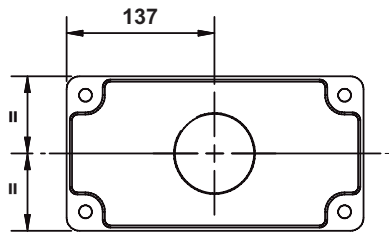

1 main entry
maximum entry size
CM75

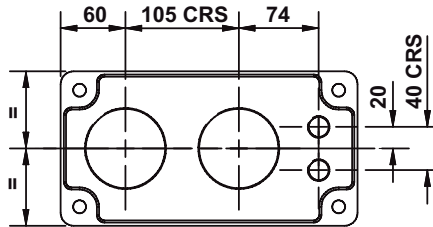

2 mains & 2 auxiliaries
maximum main entry size
CM63
auxiliary entry size
CM20

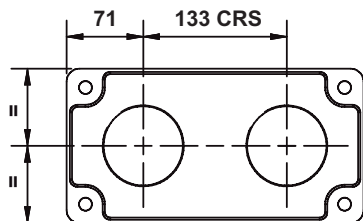

2 mains entry
maximum entry size
CM75

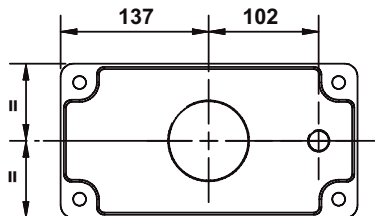

1 main & 1 auxiliary
maximum main entry size
CM75
auxiliary entry size
CM20

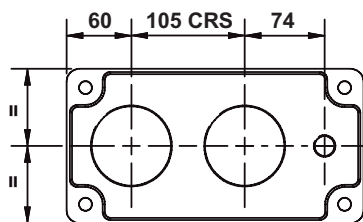

2 mains & 1 auxiliary
maximum main entry size
CM63
auxiliary entry size
CM20

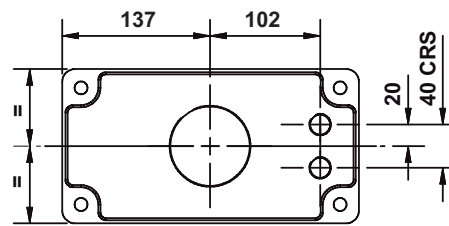

1 main & 2 auxiliaries
maximum main entry size
CM75
auxiliary entry size
CM20

The drilling and tapping sizes quoted above are for use on gland plate part number **W4LGA** only.

Please note as part of the special conditions for safe use for these range of motors.

'Any unused cable entries shall be blanked using approved cable blanks'

Europe

Brook Crompton UK Ltd

St Thomas' Road Huddersfield
West Yorkshire HD1 3LJ UK
T: +44 (0) 1484 557200
F: +44 (0) 1484 557201
E: sales@brookcrompton.com
www.brookcrompton.com

Brook Crompton UK LTD - Sede secondaria in Italia

Via De Chirico, 9/11
42124 – Reggio Emilia (RE)
T: +39 0522 345055
E: italy@brookcrompton.com
www.brookcrompton.com

Asia

Brook Crompton Asia Pacific Pte Ltd

19 Keppel Road #08-01, Jit Poh Building
Singapore 089058
T: +65 6227 0308
F: +65 6227 0605
E: marketing@brookcrompton-ap.com
www.brookcrompton.com

Brook Crompton Australia Pty Ltd

5/220 New Cleveland Road,
Tingalpa, Queensland
Australia
T: +61 (0) 721 117 280
E: salesau@brookcrompton.com
www.brookcrompton.com

Americas

Brook Crompton Inc

1100 E. 222nd Street
Euclid, Ohio 44117, USA
T: +1 800 668 6779
T: +1 - 800 463 8917
E: sales@brookcromptonna.com
www.brookcromptonna.com

Brook Crompton Ltd

264 Attwell Drive
Toronto, Ontario, M9W 5B2, Canada
T: + 416 675 3844 (Toronto)
T: +1 888 668 9843 (Quebec)
E: sales@brookcromptonna.com
www.brookcromptonna.com

Every care has been taken to ensure the accuracy of the information contained in this publication, but, due to a policy of continuous development and improvement the right is reserved to supply products which may differ slightly from those illustrated and described in this publication