

CATALOG No: **BA4M5.5V5**

ISSUED: 14-Mar-24

**GENERAL INFORMATION**

| HP  | KW   | Pole | RPM  | Frame | Voltage | Hz | Phase | IP Rating |
|-----|------|------|------|-------|---------|----|-------|-----------|
| 5.5 | 4.00 | 4    | 1800 | 112M  | 575 V   | 60 | 3     | IP55      |

| Enclosure | Ins. Class | Service Factor | Time Rating | NEMA Design | Rated Amb.   | Rated Altitude |
|-----------|------------|----------------|-------------|-------------|--------------|----------------|
| TEFC      | F          | 1.25           | Continuous  | B           | -15 to 40 C° | <3300 ft       |

**TYPICAL PERFORMANCE**

| Efficiency (%) |          |          | Power Factor (%) |          |          |
|----------------|----------|----------|------------------|----------|----------|
| Full Load      | 3/4 Load | 1/2 Load | Full Load        | 3/4 Load | 1/2 Load |
| 89.5           | 89.9     | 89.4     | 0.83             | 0.77     | 0.66     |

| LRT% | BDT % | Full Load Amps | Locked Rotor Amps | Full Load RPM |
|------|-------|----------------|-------------------|---------------|
|      |       | 575 V          | 575 V             |               |
| 180  | 300   | 7.47           | 44.30             | 1750          |

| NEMA KVA Code | Bearing Size |               | Oil Seal  |               | Sound Level |
|---------------|--------------|---------------|-----------|---------------|-------------|
|               | Drive End    | Non-Drive End | Drive End | Non-Drive End | dB(A)       |
| -             | 62062Z       | 62052Z        | -         | -             | -           |

\*Weights shown are estimated and based on standard foot mounted motor designs

**VFD DUTY INFORMATION**

|   | Variable Torque | Constant Torque | Rating                                                        |
|---|-----------------|-----------------|---------------------------------------------------------------|
| - | 6 - 60 Hz       | 12 - 60 Hz      | CSA Approved Class I; Div 2; Groups A, B, C, & D, T3 With VFD |
| - | -               | -               |                                                               |

**Click Link Below For Drawing**

[Drawing Not Available](#)

**Click Link Below For Connection Diagram**

<http://www.brookcromptonna.com/Connections/Connection%20Diagram%203%20Lead%20575%20IEC.pdf>

Notes:

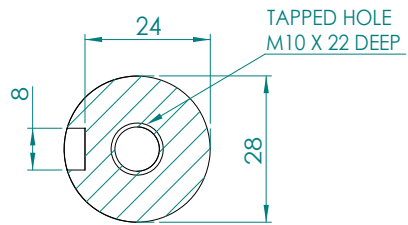
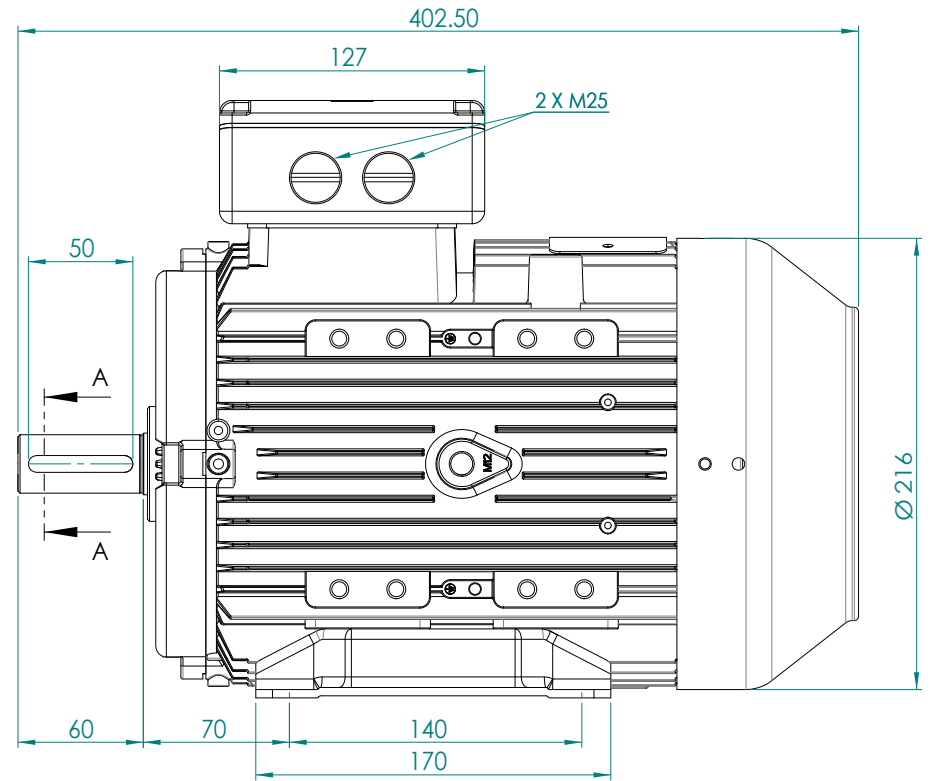
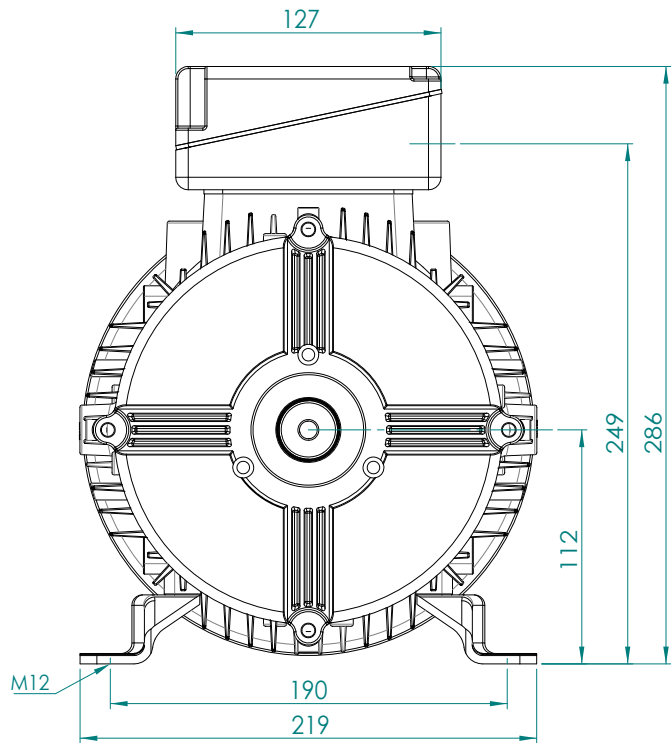

SECTION A-A  
SCALE 1 : 1

**BROOK  
CROMPTON**

WPN-DA112M\_B3\_V

A3

SHEET

www.brookcrompton.com