

CATALOG No: **BA2M1.5V5D**

ISSUED: 14-Mar-24

GENERAL INFORMATION

HP	KW	Pole	RPM	Frame	Voltage	Hz	Phase	IP Rating
1.5	1.10	2	3600	80D	575 V	60	3	IP55

Enclosure	Ins. Class	Service Factor	Time Rating	NEMA Design	Rated Amb.	Rated Altitude
TEFC	F	1.25	Continuous	B	-15 to 40 C°	<3300 ft

TYPICAL PERFORMANCE

Efficiency (%)			Power Factor (%)		
Full Load	3/4 Load	1/2 Load	Full Load	3/4 Load	1/2 Load
84.0	84.3	83.6	0.71	0.68	0.59

LRT%	BDT %	Full Load Amps	Locked Rotor Amps	Full Load RPM
		575 V	575 V	
260	300	1.86	13.75	3475

NEMA KVA Code	Bearing Size		Oil Seal		Sound Level
	Drive End	Non-Drive End	Drive End	Non-Drive End	dB(A)
-	62042Z	60032Z	-	-	-

*Weights shown are estimated and based on standard foot mounted motor designs

VFD DUTY INFORMATION

	Variable Torque	Constant Torque	Rating
-	6 - 60 Hz	12 - 60 Hz	CSA Approved Class I; Div 2; Groups A, B, C, & D, T3 With VFD
-	-	-	

Click Link Below For Drawing

[Drawing Not Available](#)

Click Link Below For Connection Diagram

<http://www.brookcrompton.com/Connections/Connection%20Diagram%203%20Lead%20575%20IEC.pdf>

Notes:

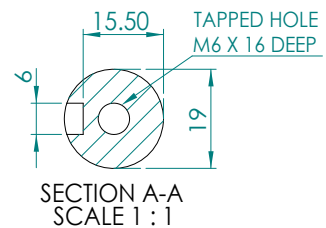
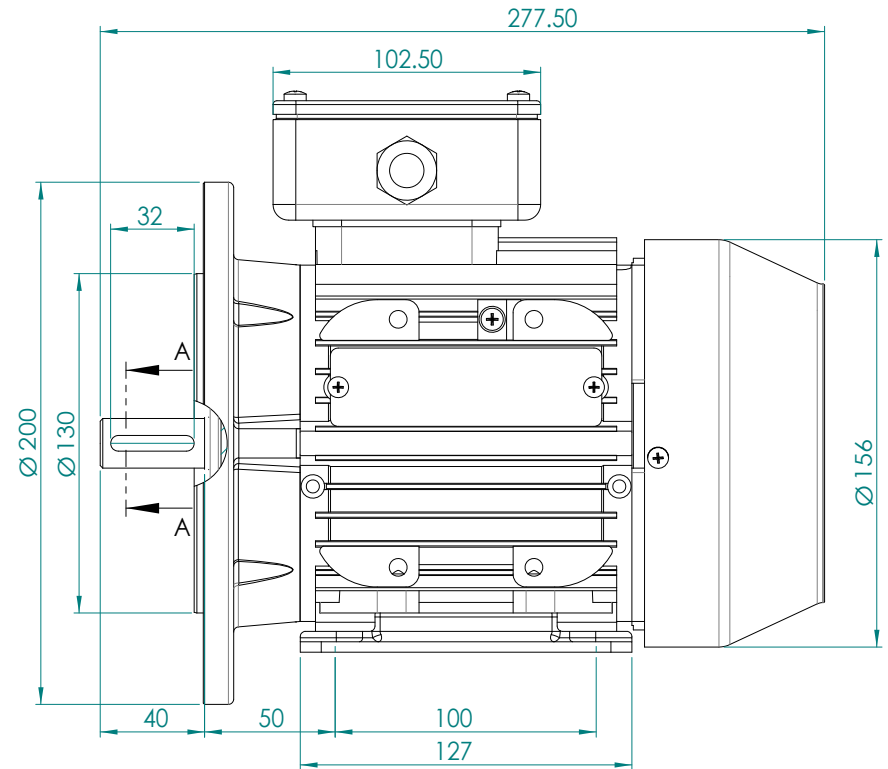
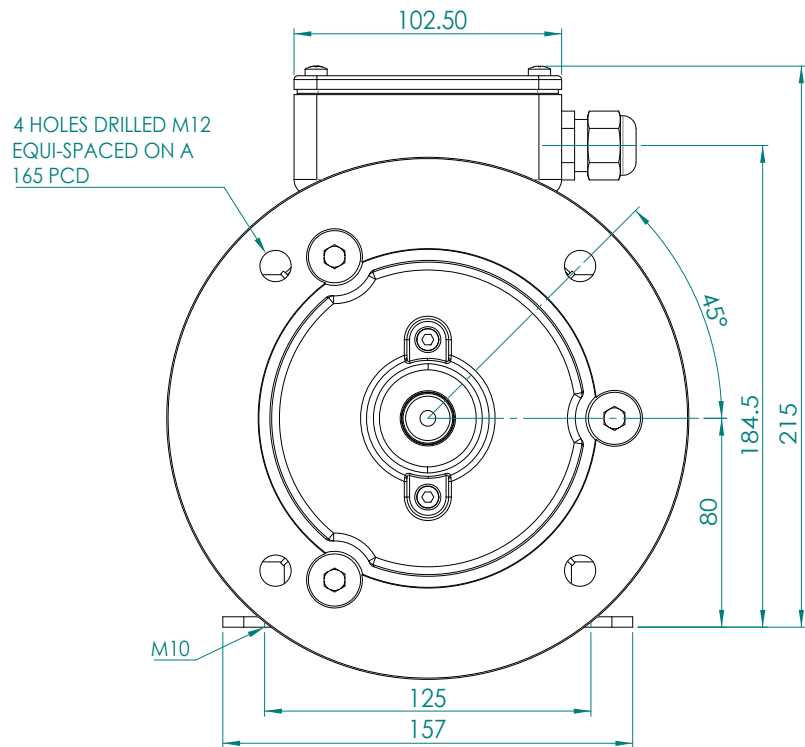

**BROOK
CROMPTON**

WPN-DA80M_B35_V

A3

SHEET

www.brookcrompton.com